

Installation Instructions

Wall Bracket Model **PSGK81**

Maximum Load **100kg**

This wall bracket should only be installed by qualified trade persons.

1. Fix the cross bar with 10mm Dyna bolts or equivalent to wall and make sure it is level.
2. Take arm assemblies and open to 90deg until it clicks into place.
3. Then take arm assemblies and fit them to the cross bar making sure it is completely supported by cross bar.
4. Move arms left or right to the required width of unit to be installed.
5. Once this is done tighten screws in arm assembly to lock it to the cross bar. Also tighten bolts at corner of arm assembly.
6. Now unscrew rubber mounts at the rear of the arm assembly until the vertical part of the arm assembly is off the supporting wall. This will assist in reducing vibration of the unit on supporting wall.
7. Place the 4 rubber mounts in to holes provided on horizontal arm assembly and adjust width of mounts according to legs of unit to be fitted.
8. Now gently position the unit onto the bracket and fasten unit into position and tighten bolts. Do not over tighten the bolts on the mounts!
9. Lastly check that all fastenings and screws are tight.

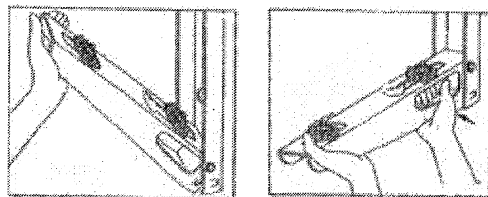
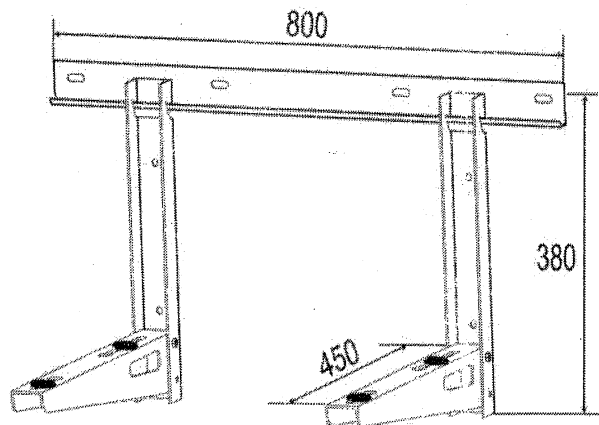

Simply unfold the arm assembly and lock into place.